



EUROPEAN LE MANS SERIES COMMITTEE



TO: Teams Manufacturers

CATEGORY: LMP2 LMP3 LMGTE

DECISION N°: 19-D0017-All-Fuel right height-BARC-PORT

DATE: 10/07/2019

FROM: The European Le Mans Series Committee

SUBJECT: Fuel rig height adjustments for the Barcelona and Portimao Competitions

APPLICABLE REGULATION

Appendix A 2019 Technical Regulations for LMP2 Prototype Homologated in 2017

Appendix A 2019 Technical Regulations for LMP3 Prototypes

Appendix 2 2019 Technical Regulations for Grand Touring Cars – LMGTE Homologated from 2016

DECISION

1/ Total height of the refuelling rig

The total height of the refuelling rig must be, at most:

- 03m25 for the Barcelona Competition
- 03m00 for the Portimao Competition

2/ Permitted adjustments

In order to achieve the height requirement for Portimao and Barcelona Competitions, it shall be permitted for those Competitions only to modify the following dimension (circled in **red**) [see page 2/2]. Modifications are subject to approval by the Technical Delegate.

PERIOD OF VALIDITY/APPLICATION OF THE DECISION

This decision comes into effect:

- with immediate application
- from: Barcelona, Portimao**

And is applicable:

- until further notice
- for the above-mentioned Competitions only**

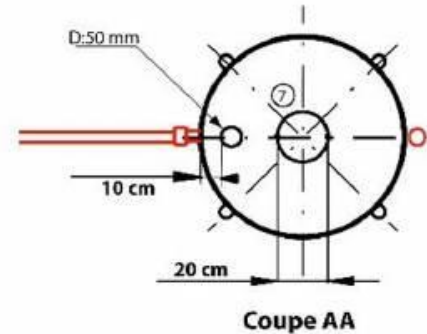
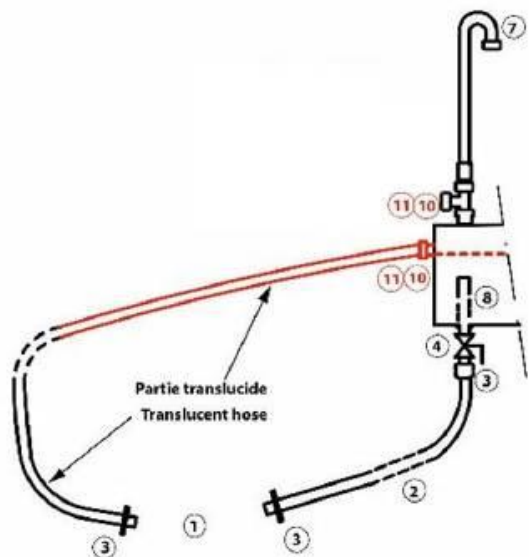

Coupe AA

- ① Accoupleurs / Male refuelling valves (dessin / drawing 252-5)
- ② Flexible de diamètre intérieur / Hose internal diameter 38mm
- ③ Raccord rapide, diamètre intérieur / Quick coupling, internal diameter 38mm
- ④ Vanne autobloquante de diamètre intérieur / Self closing valve, internal diameter 38m m
- ⑤ Orifice de remplissage (autobloquant) / Filler (dry break)
- ⑦ Arête flamme / Flame arrester
- ⑧ Restricteur / Flow restrictor (dessin / drawing 258-3)
- ⑨ Valve de séparation / Discriminator valve
- ⑩ Raccord / Coupling
- ⑪ Obturateur / Plug
- ⑫ Tube de remplissage / Filling Tube
- ⑬ Tube avec système de coupure automatique (pour Le Mans[®])
Tube with automatic shut down system (for Le Mans[®])
*Optionnel pour les autres épreuves
*Optional for the other Events
- ⑭ Raccord Auto-obturant / Self-Sealing Coupling

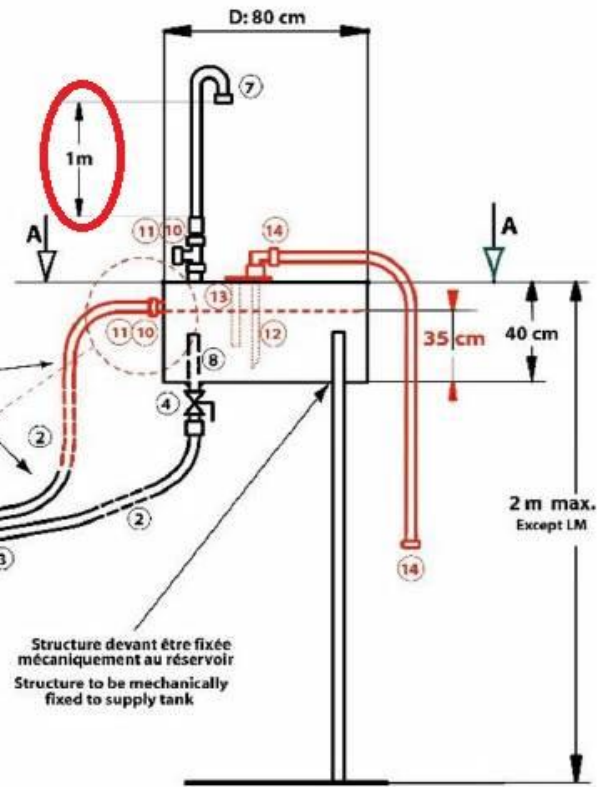

Structure devant être fixée mécaniquement au réservoir
Structure to be mechanically fixed to supply tank

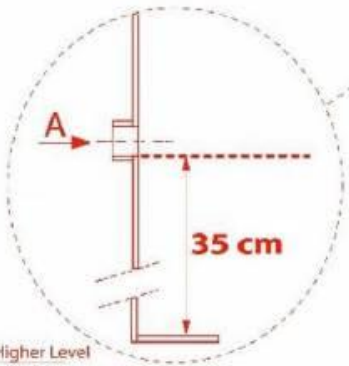

View A