



EUROPEAN LE MANS SERIES COMMITTEE



TO: Teams Manufacturers

CATEGORY: LMP2 LMP3 LMGTE

DECISION N°: ELMS20_D0015_LMGTE_BOP_Success_Ballast_C240

DATE: 04/08/2020

FROM: The European Le Mans Series Committee

SUBJECT: Success Ballast for the Le Castellet 240 Competition

APPLICABLE REGULATION

Article 6.3.4 2020 European Le Mans Series Sporting Regulations

DECISION

Please find below on page 2/4 the Success Ballast table and on page 3/4 the LMGTE BoP table.

PERIOD OF VALIDITY/APPLICATION OF THE DECISION

This decision comes into effect:

- with immediate application**
- from:

And is applicable:

- until further notice**
- for the above-mentioned Competition only

Any decision taken by the European Le Mans Series Committee is not subject to appeal.

<http://elms.alkamelsystems.com/>

| SUCCESS BALLAST | | | | | | | | | <i>Not entered in championship</i> | | | |
|---------------------------------|----|----|----|----|----|----|----|----|------------------------------------|----|----|----|
| For: | 51 | 55 | 60 | 66 | 74 | 77 | 83 | 93 | 54 | 62 | 88 | 98 |
| CASTELLET | 0 | 0 | 0 | 0 | 0 | 0 | 0 | 0 | 0 | 0 | 0 | 0 |
| SPA | 0 | 0 | 0 | 0 | 20 | 30 | 10 | 0 | 15 | 15 | 15 | 15 |
| CASTELLET 2 | 0 | 5 | 0 | 0 | 40 | 25 | 5 | 15 | 0 | 0 | 0 | 0 |
| MONZA | 0 | 5 | 0 | 0 | 15 | 0 | 0 | 10 | 0 | 0 | 0 | 0 |
| PORTIMAO | 0 | 0 | 0 | 0 | 0 | 0 | 0 | 0 | 0 | 0 | 0 | 0 |
| | | | | | | | | | | | | |
| SUCCESS BALLAST - A: Course n-1 | | | | | | | | | <i>Not entered in championship</i> | | | |
| For: | 51 | 55 | 60 | 66 | 74 | 77 | 83 | 93 | 54 | 62 | 88 | 98 |
| CASTELLET | 0 | 0 | 0 | 0 | 0 | 0 | 0 | 0 | 0 | 0 | 0 | 0 |
| SPA | 0 | 0 | 0 | 0 | 10 | 15 | 5 | 0 | 15 | 15 | 15 | 15 |
| CASTELLET 2 | 0 | 5 | 0 | 0 | 15 | 0 | 0 | 10 | 0 | 0 | 0 | 0 |
| MONZA | 0 | 0 | 0 | 0 | 0 | 0 | 0 | 0 | 0 | 0 | 0 | 0 |
| PORTIMAO | 0 | 0 | 0 | 0 | 0 | 0 | 0 | 0 | 0 | 0 | 0 | 0 |
| | 0 | 0 | 0 | 0 | 0 | 0 | 0 | 0 | 0 | 0 | 0 | 0 |
| | | | | | | | | | | | | |
| SUCCESS BALLAST - B: Course n-2 | | | | | | | | | <i>Not entered in championship</i> | | | |
| For: | 51 | 55 | 60 | 66 | 74 | 77 | 83 | 93 | 54 | 62 | 88 | 98 |
| CASTELLET | 0 | 0 | 0 | 0 | 0 | 0 | 0 | 0 | 0 | 0 | 0 | 0 |
| SPA | 0 | 0 | 0 | 0 | 0 | 0 | 0 | 0 | 0 | 0 | 0 | 0 |
| CASTELLET 2 | 0 | 0 | 0 | 0 | 10 | 15 | 5 | 0 | 0 | 0 | 0 | 0 |
| MONZA | 0 | 5 | 0 | 0 | 15 | 0 | 0 | 10 | 0 | 0 | 0 | 0 |
| PORTIMAO | 0 | 0 | 0 | 0 | 0 | 0 | 0 | 0 | 0 | 0 | 0 | 0 |
| | 0 | 0 | 0 | 0 | 0 | 0 | 0 | 0 | 0 | 0 | 0 | 0 |
| | | | | | | | | | | | | |
| SUCCESS BALLAST - C: Champ Pos | | | | | | | | | <i>Not entered in championship</i> | | | |
| For: | 51 | 55 | 60 | 66 | 74 | 77 | 83 | 93 | 54 | 62 | 88 | 98 |
| CASTELLET | 0 | 0 | 0 | 0 | 0 | 0 | 0 | 0 | 0 | 0 | 0 | 0 |
| SPA | 0 | 0 | 0 | 0 | 10 | 15 | 5 | 0 | 0 | 0 | 0 | 0 |
| CASTELLET 2 | 0 | 0 | 0 | 0 | 15 | 10 | 0 | 5 | 0 | 0 | 0 | 0 |
| MONZA | 0 | 0 | 0 | 0 | 0 | 0 | 0 | 0 | 0 | 0 | 0 | 0 |
| PORTIMAO | 0 | 0 | 0 | 0 | 0 | 0 | 0 | 0 | 0 | 0 | 0 | 0 |
| | 0 | 0 | 0 | 0 | 0 | 0 | 0 | 0 | 0 | 0 | 0 | 0 |

Any decision taken by the European Le Mans Series Committee is not subject to appeal.

<http://elms.alkamelsystems.com/>



EUROPEAN LE MANS SERIES BALANCE OF PERFORMANCE



Version: 20-2

| LMGTE AM | | CHASSIS | | | ENGINE | | | FUEL | | | ADDITIONAL COMMENTS | | |
|--------------|-------------|---------------------------------|-------------|----------------|--------------------------------------|-------------|---------|---------------------------|-------------------------------|--|---------------------|--------------|-------|
| MANUFACTURER | MODEL NAME | MINIMUM CAR WEIGHT (kg) (**) | | | 2 x MAXIMUM RESTRICTOR DIAMETER (mm) | | | MAXIMUM BOOST RATIO | DECLARED MINIMUM LAMBDA | MAXIMUM ONBOARD FUEL VOLUME (liter) | | | |
| | | prev. (1) | adjust. (2) | final (1) | prev. (1) | adjust. (2) | final | | | prev. (1) | | adjust. (2) | final |
| ASTON MARTIN | VANTAGE AMR | 1273 kg | -10 kg | 1273 kg | 30,5 mm | | 30,5 mm | See table | 0,94 | 96 l. | - | 96 l. | |
| FERRARI | 488 GTE EVO | 1270 kg | - | 1270 kg | | | | See table | 1,10 | 92 l. | - | 92 l. | |
| PORSCHE | 911 RSR GTE | 1235 kg | - | 1235 kg | 30,5 mm | | 30,5 mm | See table | 0,89 | 98 l. | - | 98 l. | |

LMGTE Am Ferrari 488 GTE

| Engine rpm | Pboost ratio Max (-) | | |
|------------|----------------------|-------------|-------------|
| | prev. (1) | adjust. (2) | final |
| 4000 | 1,70 | - | 1,70 |
| 4500 | 1,67 | - | 1,67 |
| 5000 | 1,68 | - | 1,68 |
| 5500 | 1,67 | - | 1,67 |
| 6000 | 1,60 | - | 1,60 |
| 6500 | 1,51 | - | 1,51 |
| 7000 | 1,39 | - | 1,39 |
| 7100 | 1,10 | - | 1,10 |

LMGTE Am ASTON MARTIN - VANTAGE AMR

| Engine rpm | Pboost ratio Max (-) | | |
|------------|----------------------|-------------|-------------|
| | prev. (1) | adjust. (2) | final |
| 4000 | 1,47 | - | 1,47 |
| 4500 | 1,52 | - | 1,52 |
| 5000 | 1,52 | - | 1,52 |
| 5500 | 1,53 | - | 1,53 |
| 6000 | 1,53 | - | 1,53 |
| 6500 | 1,48 | - | 1,48 |
| 7000 | 1,39 | - | 1,39 |
| 7200 | 1,36 | - | 1,36 |
| 7300 | 1,22 | - | 1,22 |

Note: Adjustments are made with the waivers required, with the data and information provided by the manufacturers until now, and with analysis made by ACO

Any decision taken by the European Le Mans Series Committee is not subject to appeal.

<http://elms.alkamelsystems.com/>

Maximum Boost Pressure Control Strategy

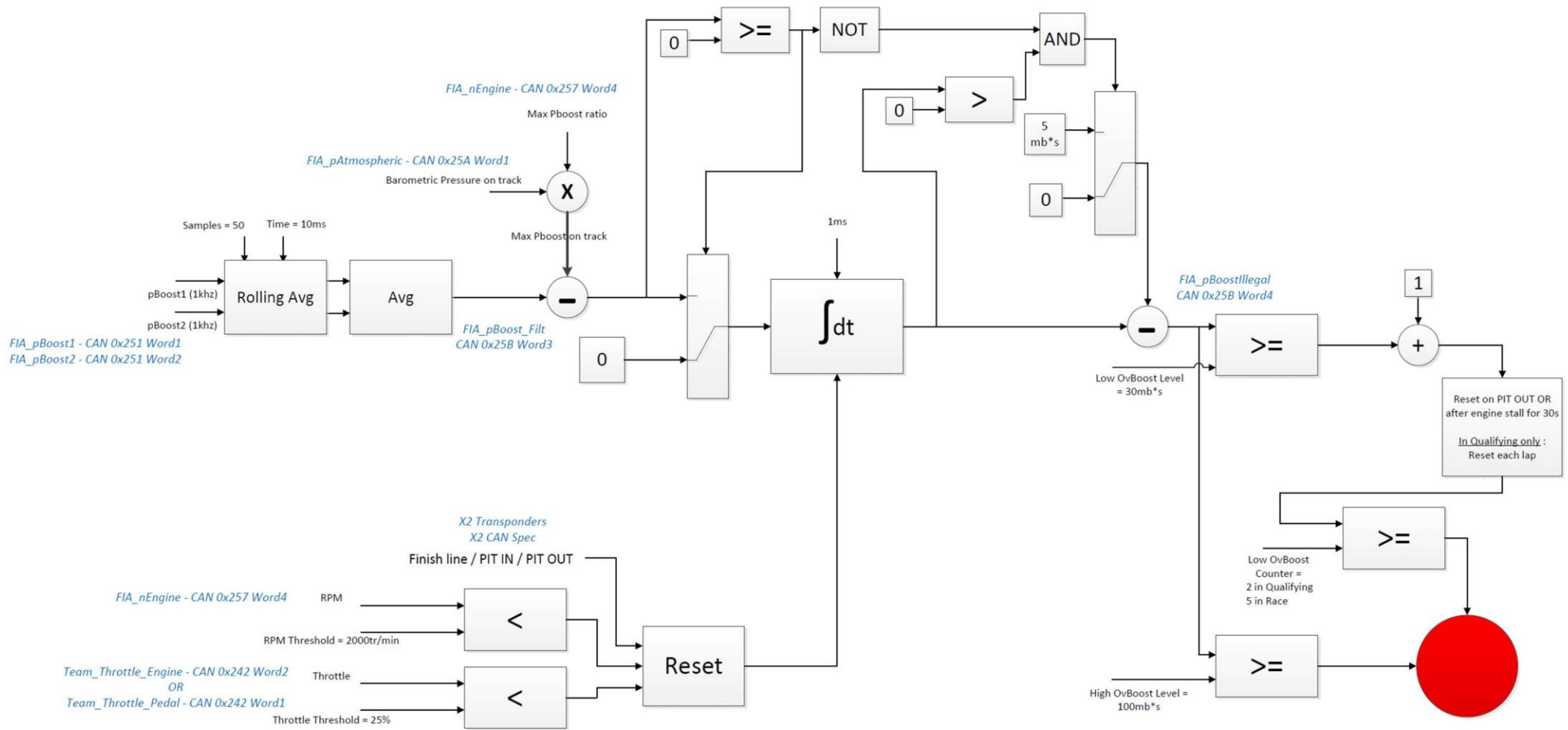

Any decision taken by the European Le Mans Series Committee is not subject to appeal.

<http://elms.alkamelsystems.com/>